

An Introduction to



Engine Protection Instrumentation



Postal Address
Homersham Ltd
P.O. Box 280
CHRISTCHURCH 8015
NEW ZEALAND

Phone: 03 3588309
Phone: 0800 659888

Website: www.homershams.co.nz

Delivery Address
Homersham Ltd
3 Homersham Place
CHRISTCHURCH 8005
NEW ZEALAND

Fax: 03 3582516
Fax: 0800 659777

E-mail: info@homershams.co.nz
Section 8



Temperature
Pressure

WHAT IS A SWICHGAGE®?

A SWICHGAGE® performs the job of two ordinary instruments (a gauge and a switch) greatly reducing necessary inventory and installation time.

Rugged monitoring SWICHGAGES® are designed for any critical control function. They are accurate and dependable.

Recommended specifically for safety shutdown on irrigation and industrial engines or as alarm systems.

Offers constant visual indication

These instruments offer a constant visual indication of the condition of any vital function on your equipment. Their precision construction meets the specifications of those applications which require a high degree of accuracy and dependability.

How a SWICHGAGE® system works?

The adjustable contact (B) is set to critical pressure point on the dial. When the earthed indicating pointer (A) makes with the adjustable contact (B) the magnetic switch coil (C) is de-energised, tripping the latch (E) which interrupts the ignition circuit and automatically shuts down the engine before serious damage can occur.

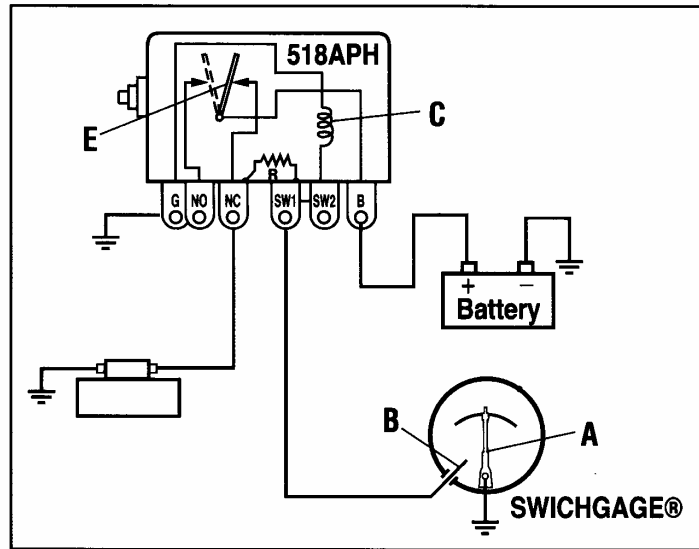

Typical Wiring with 518PH TATTLETALE®

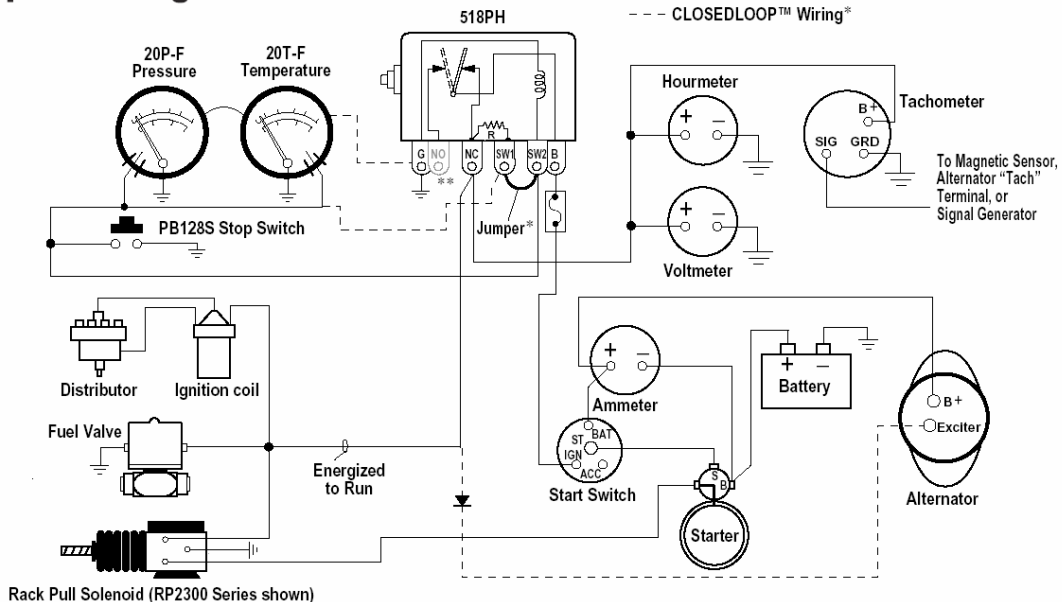

*Jumper is to be removed when connecting a CLOSEDLOOP™ circuit.
**Normally Opened terminal is available on the 518APH model.

Postal Address
Homersham Ltd
P.O. Box 280
CHRISTCHURCH 8015
NEW ZEALAND

Phone: 03 3588309
Phone: 0800 659888

Website: www.homershams.co.nz

Delivery Address
Homersham Ltd
3 Homersham Place
CHRISTCHURCH 8005
NEW ZEALAND

Fax: 03 3582516
Fax: 0800 659777

E-mail: info@homershams.co.nz
Section 8



Temperature
Pressure

20P Pressure Swichgage®

The 2" Murphy pressure swichgage® is a combination gauge and switch for alarm and/or shutdown of equipment when pre-set limits are reached.

Ranges: (dual scale psi & kPa)

15psi, 30psi, 75psi, 100psi, 150psi, 200psi, 300psi & 400psi

Accuracy: +/- 2% of full scale



20T Temperature Swichgage®

Murphy Temperature Swichgages® operate on the same principle as the pressure gauges and can be used to monitor and control water or oil temperatures.

These gauges are available in various ranges & capillary lengths. Our common stocked sizes are listed.

Range: 50-120°C, 4ft, 6ft, 12ft

Range: 150-220°C, 6ft, 10ft, 17ft



Other ranges & capillary lengths available on request.

EL150K1 Level Swichgage®

A combination level gauge and low limit switch which both indicates the level during normal operation and operates a microswitch if the level drops to the low limit set point.

Can be used with water, oil or diesel fuel.

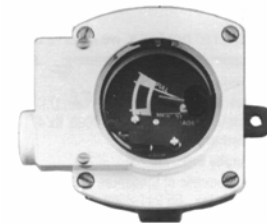

LM2000 Lube Level Maintainer

This model maintains the crankcase oil level of an engine, pump or compressor. Adjusted to the correct *running-oil-level*, the LM2000 will replenish oil as it is used, An integral, low level switch will alarm and/or shutdown the equipment id supply oil is lost and the equipment continues to use oil.



24T Timer

A mechanical timer which will stop the engine after a pre set time.

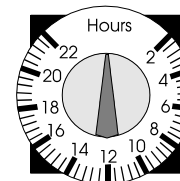

518APH Magnetic Switch

Standard shutdown magnetic switch. Any number of swichgages® or normally open switches can be connected to the 518APH.

Available in 12 or 24 VDC



Postal Address
Homersham Ltd
P.O. Box 280
CHRISTCHURCH 8015
NEW ZEALAND

Phone: 03 3588309
Phone: 0800 659888

Website: www.homershams.co.nz

Delivery Address
Homersham Ltd
3 Homersham Place
CHRISTCHURCH 8005
NEW ZEALAND

Fax: 03 3582516
Fax: 0800 659777

E-mail: info@homershams.co.nz
Section 8



Temperature
Pressure