

## Level Sensors - Horizontal Mounting

### Introduction

These miniature liquid level switches have been designed for reliable operation in small tanks and containers. Their rugged design and careful engineering make them the optimum solution for OEM and large volume applications.

### Features

- Compact Size
- Low Cost
- Reliability/long switch life
- Can be used in a wide range of liquids

### Applications

- Automatic vending machines
- Photocopiers
- Small collection tanks
- Miniature pumping stations
- Pilot plants
- Small system applications

## Specifications

Model	OLV-25S/90	OLH-32	SH10
Material			
Stem	304SS	Polypropylene	316SS
Float	316SS	Polypropylene	316LSS
Retainer	304SS	Polypropylene	316SS
Temperature	-10°C to 100°C	-10°C to 90°C	-10°C to 120°C
Pressure	20 bar	0.5 bar	10 bar
Switch	50VA AC	50VA AC	50VA AC
Lead Wires	# 22AWG	# 22AWG	# 22AWG
	300MM	300MM	300MM
Minimum SG	0.8	0.8	0.6

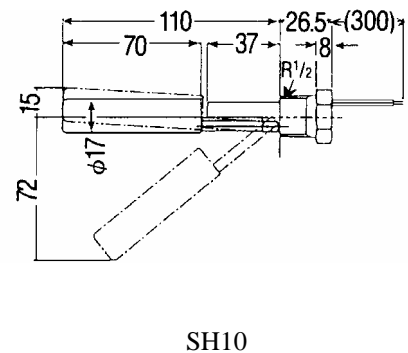
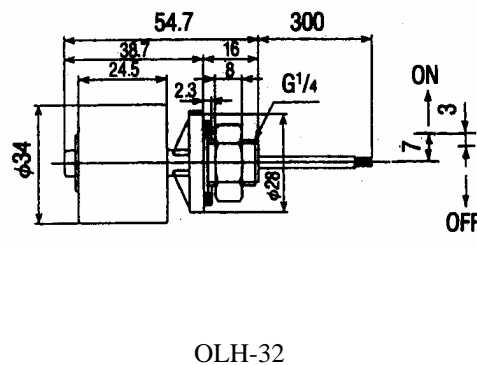
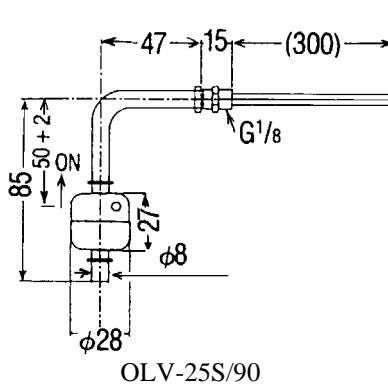

**Postal Address**  
 Homersham Ltd  
 P.O. Box 280  
 CHRISTCHURCH 8015  
 NEW ZEALAND

Phone: 03 3588309  
 Phone: 0800 659888

Website: [www.homershams.co.nz](http://www.homershams.co.nz)

**Delivery Address**  
 Homersham Ltd  
 3 Homersham Place  
 CHRISTCHURCH 8005  
 NEW ZEALAND

Fax: 03 3582516  
 Fax: 0800 659777

E-mail: [info@homershams.co.nz](mailto:info@homershams.co.nz)  
 Section 4



Temperature  
 Pressure